

Stability of Interconnected Systems under Structural Perturbation: Decomposition-Aggregation Approach

M. Kidouche, H. Habbi, and M. Zelmat

Abstract—In this paper, the decomposition-aggregation method is used to carry out connective stability criteria for general linear composite system via aggregation. The large scale system is decomposed into a number of subsystems. By associating directed graphs with dynamic systems in an essential way, we define the relation between system structure and stability in the sense of Lyapunov. The stability criteria is then associated with the stability and system matrices of subsystems as well as those interconnected terms among subsystems using the concepts of vector differential inequalities and vector Lyapunov functions. Then, we show that the stability of each subsystem and stability of the aggregate model imply connective stability of the overall system. An example is reported, showing the efficiency of the proposed technique.

Keywords—Composite system, Connective stability, Lyapunov functions.

I. INTRODUCTION

IN recent years in automatic control theory, very often we encounter the problem of investigating complex multidimensional systems. In principle the classical methods, in particular the direct method of Lyapunov [15], may be applied for solving these problems. In practice, however, their application meets with great computational difficulties which increase rapidly as the system's order grows [11]. The main difficulty in the application of Lyapunov method is that there is no obvious choice for a function suitable for use as a Lyapunov function. The general question on the existence of such functions remains completely open. Application of the Lyapunov method can effectively realized for lower order systems [12, 13, 20]. Attempts to get rid of some of these difficulties have led to the application of the Bellman [3] and Bailey [2] decomposition aggregation approach. They used the concept of vector Lyapunov function in their applications of Lyapunov method to the investigation of complex systems.

Manuscript received October 4, 2007. This paper was completed in Applied Automation Laboratory at University of Boumerdes. This work was supported by the Minister of Higher Education and Scientific Research.

M. Kidouche is with the department of Automation, Boumerdes, Algeria (e-mail: kidouche_m@hotmail.com).

H. Habbi is with the department of Automation, Boumerdes, Algeria (e-mail: habbi_hacene@hotmail.com).

A Lyapunov function is found for each individual subsystem. Next, all these functions are interconnected into a single vector Lyapunov function. The nature of this interconnection is determined by the structure of the system being investigated. The use of such an approach avoids the technical difficulties usually arising when Lyapunov's method is directly applied to the investigation of high-order systems.

Over the years a large number of extensions and applications of the connective stability concept have been proposed. A wide variety of structural perturbations have been studied, starting as unknown but bounded functions of time and state [24, 25]. Subsequently, modeling of uncertain interconnection matrices has been broadened to include stochastic elements [7, 14], expanding the size of complex systems [6, 26] impulse and hybrid systems [8, 17] singular perturbations [27] matrix Lyapunov functions [18]. At the outset of modeling complex systems, which are composed of interconnected subsystems, directed graphs have been introduced [22, 24] to define and interpret the interconnection structure underlying the dynamics of the interacting structure. Subsystems were associated with vertices while interconnections with edges of the graph. In order to allow accidental and intentional changes in the interconnection structure, which are always present in real world applications, the graph was assumed to vary as a function of time and the state of the systems. To capture the effect of changing structure on the stability of large complex systems, the concept of connective stability was introduced as Lyapunov's stability under structural perturbation. This opens up the possibility of using the powerful Lyapunov's direct method to derive suitable conditions for connective stability. By decomposing a composite system into interconnected subsystems and aggregating the stability properties of subsystems by appropriate Lyapunov functions, we will form an aggregate model of the system which involves a vector Lyapunov function [19, 21]. Stability of each subsystem and stability of the aggregate model imply connective stability of the overall system. Our objective is to initiate a systematic study of dynamic interconnections within complex systems using the proposed concept.

II. PROBLEM FORMULATION

We consider a linear time invariant system (S) represented by the state variable differential equation:

$$\dot{x} = Ax \tag{1}$$

where x is n - dimensional state, and A is an $n \times n$ constant matrix. It is natural to assume that a large plant (1) is composed of interconnected subsystems given by:

$$\dot{x}_i = A_i x_i + \sum_{j=1}^N e_{ij} A_{ij} x_j \quad i=1, 2, \dots, N \tag{2}$$

where $x_i \in R^{n_i}$ are the state vectors of the i^{th} subsystem, A_i and A_{ij} are $n_i \times n_i$ and $n_i \times n_j$ real matrices respectively. The interconnection parameters $e_{ij} \in [0,1]$ are coefficients of the $N \times N$ interconnection matrix E , which are used to model the strength of interconnections. The concept of connective stability was first introduced by Siljak [24], to address the robust stability of large scale systems. Its main objective is to capture uncertainty residing in the interconnections of composite systems. To minimize the length of the text of this section, a concise description is presented. An $N \times N$ matrix $E(t)$ with element $e_{ij}(t)$ and an $N \times N$ constant binary matrix \bar{E} with element \bar{e}_{ij} can be introduced for the study of the uncertainty and the stability condition of a large scale system consisting of N subsystems. The value of $e_{ij}(t)$ and the corresponding value of \bar{e}_{ij} can belong to one of the following:

- (a) $e_{ij}(t) = 0 \quad \forall t \in T$, corresponding $\bar{e}_{ij} = 0$
- (b) $e_{ij}(t) \in [0 \ 1] \quad \forall t \in T$, correspondingly $\bar{e}_{ij} = 1$

The required detailed definitions and results can be found in [24].

Due the physical considerations or mathematical manipulations many such systems are regarded as interconnection of the following subsystems:

The n isolated subsystems of the system (2) are given by the equations:

$$\dot{x}_i = A_i x_i \tag{3}$$

The term $e_{ij} A_{ij} x_j$ is used to represent the interconnection and the uncertainty involved when $j \neq i$. Our aim is to find the connective stability of the composite system (1) for all $e_{ij} \in [0,1]$. A classical way to prove connective stability of

(1) for equilibrium $x^* = 0$ is to use the Matrosov-Bellman concept of vector Lyapunov function [16]. Before we do so, we introduce first the concept of the decomposition.

III. DECOMPOSITION

Systems involving a large number of variables are difficult to consider in one piece. Despite the high efficiency of modern computers, the formidable complexity of a large system can make the problem numerically intractable even with the most valuable one shot techniques. It has long been recognized that certain complex systems made of interacting elements can be decomposed into subsystems of lower dimensionality. The separate solutions of the subsystems are combined together in some way to provide a solution system. While the decomposition principle can bring about a great

saving in solution time over solving the whole system in one piece, it is still highly dependent on the choice of a particular decomposition.

We now outline the decomposition-aggregation method for connective stability analysis of the linear constant interconnected system (S) described by (1). We can partition the state vector x into two vector components:

$$x_1 = (x_{11}, x_{12}, \dots, x_{1n_1})^T, \quad x_2 = (x_{21}, x_{22}, \dots, x_{2n_2})^T$$

where we have renamed the components of the vector x in an obvious way. To study connective stability of the equilibrium $x^* = 0$, we assume that the system (2) is decomposed into two interconnected subsystems $x = (x_1, x_2)^T$ namely S_1 and S_2 , that is:

$$\dot{x}_1 = A_1 x_1 + e_{12}(t) A_{12} x_2 \tag{4a}$$

$$\dot{x}_2 = A_2 x_2 + e_{21}(t) A_{21} x_1 \tag{4b}$$

which can be obtained from (1) by assuming the matrix \bar{E} to have the form:

$$\bar{E} = \begin{bmatrix} 0 & 1 \\ 1 & 0 \end{bmatrix} \tag{5}$$

And replacing its elements with the elements $e_{ij}(t)$ for $i, j = 1, 2$ of the matrix E .

Now, we consider the stability of each decoupled linear constant subsystem δ_i for $i = 1, 2$ given respectively by:

$$\dot{x}_i = A_i x_i \tag{6}$$

Since we want to establish stability of (S), we require that δ_i are stable. To have stability of δ_i we propose the scalar functions:

$$v_i(x_i) = (x_i^T H_i x_i)^{1/2} \tag{7}$$

as candidates for the Lyapunov functions of the subsystems, and require that for any choice of the positive definite matrices G_i there exist positive definite matrices H_i as solutions of the Lyapunov matrix equations:

$$A_i^T H_i + H_i A_i = -G_i \tag{8}$$

The total time derivative of $v_i(x_i)$ for $i = 1, 2$ along the solution of (6) is:

$$\dot{v}_i = (\text{grad } v_i)^T \dot{x}_i = -\frac{1}{2} v_i^{-1/2} (x_i^T G_i x_i) \tag{9}$$

where we have used:

$$\text{grad } v_i = v_i^{-1} x_i^T H_i \tag{10}$$

Finally, from equation (8), (9) and (10) we produce the estimates for the Lyapunov functions $v_i(x_i)$ as:

- (i) $\alpha_{i1} \|x_i\| \leq v_i \leq \alpha_{i2} \|x_i\|$
- (ii) $\dot{v}_i \leq -\alpha_{i3} \|x_i\|$
- (iii) $\|\text{grad } v_i\| \leq \alpha_{i4}$

where the positive number α_{ij} are calculated as:

$$\begin{aligned} \alpha_{i1} &= \lambda_m^{1/2}(H_i) & \alpha_{i2} &= \lambda_M^{1/2}(H_i) \\ \alpha_{i3} &= \frac{1}{2} \frac{\lambda_m(G_i)}{\lambda_M^{1/2}(H_i)} & \alpha_{i4} &= \frac{1}{2} \frac{\lambda_M(H_i)}{\lambda_m^{1/2}(H_i)} \end{aligned} \quad (12)$$

Here λ_m and λ_M are the minimum and maximum eigenvalues of the indicated matrices.

Conditions (i and ii) imply that the Lyapunov functions for each subsystem are positive definite, decrescent and radically unbounded; and that the isolated subsystems are all asymptotically stable.

Condition (iii) shows that the bound on the gradient Lyapunov functions is on the magnitude only and takes into consideration the stabilizing effect of the interconnection interactions.

We use the Lyapunov functions $v_i(x_i)$ as indices of stability for each subsystem δ_i to investigate the stability of the overall system. Let us take the total time derivative $\dot{v}_{(3.1)}$ along the solutions of the interconnected subsystem δ_i of (4)

$$\begin{aligned} \dot{v}_{i(3.1)} &= (\text{grad } v_i)^T \dot{x}_i = (\text{grad } v_i)^T [A_i x_i + e_{ij}(t) A_{ij} x_j] = \\ &\dot{v}_{i(3.3)} + (\text{grad } v_i)^T e_{ij}(t) A_{ij} x_j \quad i, j = 1, 2 \end{aligned} \quad (13)$$

By taking the norm on the right-hand side of (13) and using the estimate $-\alpha_{i3} \|x_i\|$ for $\dot{v}_{i(3.3)}$ of (11) we get from (13):

$$\dot{v}_i \leq -\alpha_{i3} \|x_i\| + e_{ij}(t) \|\text{grad } v_i\| \|A_{ij} x_j\| \quad (14)$$

If we use the constraint on interactions as:

$$\|A_{ij} x_j\| \leq \eta_{ij} \|x_j\| \quad (15)$$

where $\eta_{ij} = \lambda_M^{1/2}(A_{ij}^T A_{ij})$ and from the estimates (3.8) express $\|x_i\| \geq \eta_{i2}^{-1} v_i$, then we can rewrite the inequalities (14) as:

$$\begin{aligned} \dot{v}_1 &\leq -\alpha_{12}^{-1} \alpha_{13} v_1 + e_{12}(t) \eta_{12} \alpha_{14} \alpha_{21}^{-1} v_2 \\ \dot{v}_2 &\leq e_{21}(t) \eta_{21} \alpha_{24} \alpha_{12}^{-1} v_1 - \alpha_{22}^{-1} \alpha_{23} v_2 \end{aligned} \quad (16)$$

Now we define the vector Lyapunov function as:

$$v = (v_1, v_2)^T \quad (17)$$

And rewrite the scalar inequalities (16) as one vector inequality [4], [9]

$$\dot{v} \leq W v \quad (18)$$

which involves only the vector Lyapunov function v and represent the aggregate model \mathcal{A} for the overall system (S) defined in (1). The aggregate 2×2 matrix $W = w_{ij}$ is defined as:

$$w_{ij} = \begin{cases} -\alpha_{i2}^{-1} \alpha_{i3} & i = j \\ e_{ij}(t) \eta_{ij} \alpha_{j1}^{-1} \alpha_{i4} & i \neq j \end{cases} \quad (19)$$

To complete our investigation, we should prove that connective stability of the overall system (S) follows from

stability of the aggregate model \mathcal{A} . To show this, we will first establish a comparison result for vector differential inequalities and majorize the function $v(t)$ that satisfy the inequality (18) by solutions $r(t)$ of the equation:

$$\dot{r} = \bar{W} r \quad (20)$$

when $v_0 = r_0$. Here $\bar{W} = \bar{w}_{ij}$ is the aggregate matrix which corresponds to the fundamental matrix \bar{E} defined in (5),

$$\bar{w}_{ij} = \begin{cases} -\alpha_{i2}^{-1} \alpha_{i3} & i = j \\ e_{ij} \eta_{ij} \alpha_{j1}^{-1} \alpha_{i4} & i \neq j \end{cases} \quad (21)$$

If the matrix is stable (that is Metzler matrix) [1], and for all:

$$\begin{aligned} E &= E(t), \\ v(t) &\leq r(t), \quad t \geq t_0 \end{aligned} \quad (22)$$

then from $v(t) \geq 0$ we conclude $\lim_{t \rightarrow \infty} v(t) = 0$, so

$$\dot{v} \leq \bar{W} v \quad (23)$$

and thus the connective stability of (S).

Finally, we conclude from the inequality (22) and the choice of nonnegative function $v_i(x_i)$ $i = 1, 2$, which satisfy the aggregate model \mathcal{A} of (18), that stability of the constant matrix \bar{W} is sufficient for connective stability of the overall system.

IV. EXAMPLE

To illustrate some aspects of the decomposition of physical systems, let us consider the spring-mass-damper shown in Fig. 1.

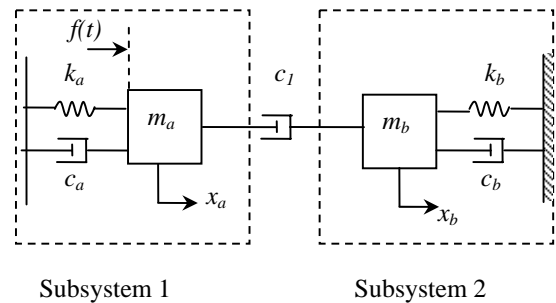

Fig. 1 A Spring-mass-damper system

The equations of motion are:

$$\begin{aligned} m_a \ddot{x}_a + k_a x_a + c_a \dot{x}_a + c_1 (\dot{x}_a - \dot{x}_b) &= f(t) \\ m_b \ddot{x}_b + k_b x_b + c_b \dot{x}_b + c_1 (\dot{x}_b - \dot{x}_a) &= 0 \end{aligned} \quad (24)$$

The equation of motion (24) can be rewritten in the state form for $f(t) = 0$ as:

$$\begin{bmatrix} \dot{x}_1 \\ \dot{x}_2 \\ \dot{x}_3 \\ \dot{x}_4 \end{bmatrix} = \begin{bmatrix} 0 & 1 & 0 & 0 \\ -\frac{k_a}{m_a} & -\frac{c_a+c_1}{m_a} & 0 & \frac{c_1}{m_a} \\ 0 & 0 & 0 & 1 \\ 0 & \frac{c_1}{m_b} & -\frac{k_b}{m_b} & -\frac{c_b+c_1}{m_b} \end{bmatrix} \begin{bmatrix} x_1 \\ x_2 \\ x_3 \\ x_4 \end{bmatrix} \quad (25)$$

Assume the parameter values $k_a = k_b = 1, m_a = m_b = 1$ and $c_a = c_b = 1$. We can decompose (25) into two interconnected subsystems:

$$\dot{x}_1 = \begin{bmatrix} 0 & 1 \\ -1 & -1 \end{bmatrix} x_1 + \begin{bmatrix} 0 & 0 \\ 0 & -c_1 \end{bmatrix} x_1 + \begin{bmatrix} 0 & 0 \\ 0 & c_1 \end{bmatrix} x_2 \quad (26)$$

$$\dot{x}_2 = \begin{bmatrix} 0 & 1 \\ -1 & -1 \end{bmatrix} x_2 + \begin{bmatrix} 0 & 0 \\ 0 & -c_1 \end{bmatrix} x_2 + \begin{bmatrix} 0 & 0 \\ 0 & c_1 \end{bmatrix} x_1$$

where the states of the subsystems are $x_1 = (x_{11}, x_{12})^T = (x_a, \dot{x}_a)$ and $x_2 = (x_{21}, x_{22})^T = (x_b, \dot{x}_b)$. We are interested in estimating the region of stability for the interconnecting damper parameter c_1 . From (26) we see that the damper parameter c_1 appears only in the interconnections between the two subsystems. Therefore, the chosen decomposition will allow us to study explicitly the effect on overall system stability of varying the damper c_1 .

We choose the functions $v_i(x_i)$ as in (7) and solve the Lyapunov matrix equations (8) for A_i ($i=1,2$) given in (26) and

$$G_i = \begin{bmatrix} 1 & 0 \\ 0 & 1 \end{bmatrix} \quad (27)$$

to get

$$H_i = \begin{bmatrix} 1.5 & 0.5 \\ 0.5 & 1 \end{bmatrix} \quad (28)$$

and the estimates (11) as:

$$\alpha_{i1} = 0.83, \alpha_{i2} = 1.35, \alpha_{i3} = 0.37, \alpha_{i4} = 2.18 \quad (29)$$

The constraints (15) are calculated for A_{ij} ($i, j=1,2$) to get

$$\eta_{ij} = c_1.$$

By using the modified aggregate matrix (20) given by:

$$\bar{w}_{ij} = \begin{cases} -\alpha_{i2}^{-1} \alpha_{i3} + \bar{e}_{ij} \eta_{ij} \alpha_{i1}^{-1} \alpha_{i4} & i = j \\ \bar{e}_{ij} \eta_{ij} \alpha_{j1}^{-1} \alpha_{i4} & i \neq j \end{cases} \quad (30)$$

since now

$$\bar{E} = \begin{bmatrix} 1 & 1 \\ 1 & 1 \end{bmatrix} \quad (31)$$

we get the aggregate model (23) as:

$$\dot{v} \leq \begin{bmatrix} -0.276 + 2.62c_1 & 2.62c_1 \\ 2.62c_1 & -0.276 + 2.62c_1 \end{bmatrix} \quad (32)$$

We use the M-Matrix to determine stability of the aggregate matrix \bar{W} in (32). And we have the stability region for the parameter c_1 if $0 \leq c_1 \leq 0.13$.

The above example illustrate the parametric aspect of the vector Lyapunov function: The effect of changing parameters in interactions can be studied explicitly.

V. CONCLUSION

Connective stability concept can be used in a suitable way to explore conditions for a breakdown of complex dynamic system due to failures of their components or subsystems. This use, however should involve the system structure in an essential way. In our approach we have formulated connective stability for an interconnected linear system in term of vector Lyapunov function and comparison principle. Lyapunov's method is an ideal mechanism for accomplishing the aggregation plan in the stability analysis of interconnected dynamic systems. However this approach which is based on decomposition-aggregation, simplifies the stability problem, but sacrifices detailed information about the size of variations of each separate state variable.

REFERENCES

- [1] M. Araki, "Application of M-matrix to the stability problems of composite system" Journal of mathematical analysis and application, No. 52, pp. 309-321, 1975.
- [2] F. N. Bailey "The application of Lyapunov's second method to interconnected systems" SIAM Journal of control, No. 3, pp. 443-462, 1966.
- [3] R. Bellman, "Vector Lyapunov functions", SIAM Journal of control, vol.1, pp. 32-34, 1962.
- [4] S. Boyd, L. E. Ghaoui, E. Feron, and V. Balakrishnan "Linear matrix inequalities in system and control theory" Philadelphia, PA: SIAM, 1994.
- [5] F. H. Clark, Yu. S. Ledyev "Nonsmooth analysis and control theory" New-York: Springer-Verlag, 1998.
- [6] R. Cogill, S. Lall "Control design for topology independent stability of interconnected systems".
- [7] B. L. Griffin, G. S. Ladde "Qualitative properties of stochastic iterative processes under random structural perturbations" Mathematics and Computers in simulation, pp. 181-200, 67/2004.
- [8] W. M Haddad, V. Chellaboina "Impulsive and Hybrid dynamical systems" Princeton University Press, Princeton NJ 2006.
- [9] R. A. Horn and C. R. Johnson "Topics in matrix analysis" Cambridge, UK: Cambridge University Press, 1991.
- [10] T. Hu and Z. Lin "Properties of the composite quadratic Lyapunov functions" IEEE Trans. on Automatic Control, vol.49, No.7, pp. 1162-1167, July 2004.
- [11] M. Jamshidi "Large-scale systems: Modeling, control, and fuzzy logic" Prentice Hall, Inc., New-Jersey, 1997.
- [12] M. Kidouche and A. Charef "A constructive methodology of Lyapunov functions of composite systems with nonlinear interconnection term" International Journal of Robotics and Automation, vol.21, No.1, pp. 19-24, 2006.
- [13] M. Kidouche "The variable gradient method for generating Lyapunov functions of nonlinear composite system" 11th IEEE International Conference on Methods and Models in Automation and Robotics, Miedzydroje, Poland, pp.233-237, Aug. 2005.
- [14] G. S. Ladde, D. D. Siljak "Multiplex Control Systems: Stochastic stability and dynamic reliability" International Journal of Control, NO. 38, pp. 514 - 524, 1983.
- [15] V. Lakshmikantham, et al. "Vector Lyapunov functions and stability analysis of nonlinear systems" Dordrecht, The Netherlands: Kluwer Academic Publishers, 1991.
- [16] V. M. Matrasov "On theory of stability of motion" Prikladnia Matematika I Mekhanika, vol.26, pp. 992-1000, 1962.

- [17] V. M. Matrasov "Nonlinear Control theory and Applications" Fizmatlit, Moscow 2000.
- [18] A. A. Martynyuk "Novel stability and instability conditions for interconnected systems with structural perturbations" Dynamics of continuous discrete and impulsive systems, NO. 7, pp. 307 – 324, 2000.
- [19] A. N. Michel, B. Hu "Stability analysis of interconnected hybrid dynamical systems" in Proc. IFAC symposium on large scale system, 1998.
- [20] A. N. Michel "Qualitative analysis of dynamical systems, 2nd ed. New-York: Marcel Dekker, 2001.
- [21] A. Papachristodoulou and S. Prajma "On the construction of Lyapunov functions using the sum of squares decomposition" Proc. of the 41st IEEE Conference on Decision and Control, Las Vegas, Nevada, USA, pp. 3482-3486, Dec. 2002.
- [22] D. Reinhard "Graph theory" 2nd Ed. New-York: Springer Verlag, 2000.
- [23] S. Ruan "Connective stability of competitive equilibrium" Journal of mathematical analysis and applications, vol. 160, pp. 480-484, 1991.
- [24] D. D. Siljak "Decentralized control of complex systems" Academic Press, New-York, 1991.
- [25] D. D. Siljak "Connective stability of discontinuous interconnected systems via parameter dependent Lyapunov functions" in Proc. of the American control conference Arlington, VA, pp. 4189-4196, 2001.
- [26] X. L. Tan, M. Ikeda "Decentralized stabilization for expanding construction of large scale systems" IEEE Transactions on Automatic Control NO. 35, pp. 644 – 651, 1990.
- [27] H. C. Tang, D. D. Siljak "A learning scheme for dynamic neural networks: Equilibrium manifold and connective stability" Neural Networks, NO. 8, pp. 853 – 864, 1995.