

A Power Line Communication Control Scheme for Electrical Energy Management

Mohamed Zoubir SAIDI, Hamid BENTARZI, and Larbi REFOUFI
Signals & Systems Laboratory
Institute of Electronics and Electrical Engineering
Boumerdes university
Avenue of independence, 35000,
e-mail: sisylab@yahoo.com
ALGERIA

Abstract: - In the present paper is described the scheme of a Power Line Communication (PLC) control system for energy management. The control system described is based on the Spread Spectrum Carrier Technology (SSCT) for the transmission of control information over the power line. This technique employs a series of short frequency swept chirps that act as carrier. The swept frequency chirps are generated by the implementation of a look up table stored in a ROM section. The choice of using a ROM is based on a hardware solution that allows the chirps generation under accurate timing. Another reason is the possibility to generate the chirps in their different modulated forms. Information data is converted to chirps according to the Consumer Electronics Bus (CEBus) standard that sets the transmission protocols and the modulation technique. Energy management to be achieved requires the control of various devices existing in buildings and houses and leading to the concept of Home Automation.

Key-Words: - Power Line Communication, Spread Spectrum Carrier Technology (SSCT), Energy management.

1 Introduction

Many reasons can be accounted for the use of power line as a medium of communication. Electricity companies are seeking to develop new ways to automate their usual operations namely the energy management and customers billing [1]. The ever growing number of domestic appliances and multimedia equipments has augmented the awareness of their users for energy management. The proliferation of office equipments in business building has led to the need of interconnecting them for the purposes of resource sharing [2].

The use of the electrical power distribution system is arguably the preferable communication medium among the most used (RF, twisted cable, coaxial cable, telephone cable, infra red, and optical fiber). The wiring is already in place. The lines are almost universal in coverage and are easily accessed through any wall socket. This allows the equipments to be portable and the network easily reconfigurable. However the power distribution was not designed for data transmission and represents a hostile environment for a digital communication system. Attenuation changes from point to point being a random function of the time and the frequency of connection of various load devices [3]. Consequently, the realization of the proposed project is two-fold. First is the use of the recent and available communication technology to overcome the problem of noise and interferences present in the ac conductors. Second is the use of an established standard for Home automation to attain the projected goals. The

communication scheme chosen here includes the Spread Spectrum Technology for the transmission of information onto the power line media and the coding of information adopted by the Consumer Electronics Bus (CEBus) standard as the modulation technique.

2 Power Line Communication: features and problems

Power line is becoming a very attractive medium for a variety of applications such as the industrial control and monitoring and the latest networked multimedia. With bridges or routers to other mediums, very high interoperations are achieved between domestic appliances, entertainment equipments, Internet, and mobile communications. However, the faced problems are due to a hostile environment where noise levels are often severe.

Noise and disturbances are of different natures. There are wave shape disturbances due to over voltage, under voltage, outage, frequency variations, and harmonic disturbances. There are also superimposed disturbances due to persistent oscillations (coherent or random), and transient disturbances (impulse and damped oscillations) [4]. Nonetheless, in developing PLC communication systems appropriate error correcting codes and modulation techniques should be employed to reduce noise and disturbances effects. Spread Spectrum Carrier technology is used for it is the most adequate technique to combat the interferences by using frequencies far away from the disturbing ones. Coding of information, as

modulating technique set by the CEBus, together with an error detecting scheme insure the transmission and reception of data despite severe noise.

3 Spread Spectrum Carrier Technologies

Spread Spectrum Carrier Technology (SSCT) is a technique of spread spectrum communications appropriate for point-to-point or Carrier Senses Multiple Access (CSMA) technique. It is a method by which a series of short, self-synchronizing, frequency swept “chirps” act as a carrier. As in traditional direct sequence systems, the chirp effectively spreads the signaling energy over a broad frequency range. Since it applies to broad frequencies, SSCT can maintain strong immunity in hostile environments and makes itself suitable for communication on AC lines. The chirps are always of the same known pattern and detectable by all the nodes on the network. In the case of the Electronics Industries Association (EIA) which developed the CEBus standard the signal is spread over a frequency range of 100kHz to 400kHz over a duration of 100µs, with an effective bit rate of 10Kb/s. In Europe, the systems developed spread the signal over a frequency range of 20 kHz to 80 kHz, with a lower bit rate of 2kb/s. Theoretically, the frequency sweeping of the chirp should range from 100 to 400 kHz, but a practical implementation as designed by Intellon Corp begins and ends the frequency sweep at 200 kHz with a transition from 400 to 100 kHz in the middle [5]. The reasons for this type of arrangement are due to the needs to simplify the filtering required to limit the harmonic energy and to allow a smooth transition between data bits. Figure 1 illustrates the SSC power line chirp [6].

This signaling technique allows the development of very low cost yet efficient spread spectrum transceiver devices. The swept frequency signal can be generated by the implementation of a simple lookup table stored in a ROM section.

In a CEBus packet, data is encoded using pulse width encoding to represent the symbols “1”, “0”, “End of Field” (EOF), and “End of Packet” (EOP). The minimum symbol period is defined as the Unit Symbol Time (UST). The length of one UST is 100µs during the packet body. This unit of time equals the shortest symbol time that is the symbol “1”. For longer symbol times, the chirp repeats for a multiple of the UST. A quiet time of 14µs is added to the chirp during the preamble body. Table 1 gives the symbols in terms of UST.

During the preamble part, there is a superior state that represents the presence of chirp, and an inferior state that represents the absence of the chirp. This type of modulation is known as Amplitude Shift Keying (ASK). Inferior state or superior state are not respectively and exclusively related to symbol “1” or “0”, but they alternate at each data symbol occurrence.

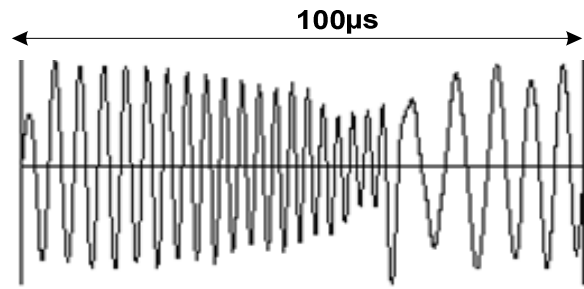

Figure 1. Spread Spectrum Carrier Chirp

Table 1 Encoding symbols

SYMBOL	PREAMBLE		NON PREAMBLE (Packet Body)	
	UST TIME	TIMING	UST TIME	TIMING
“1”	1	114 µs	1	100 µs
“0”	2	228 µs	2	200 µs
“EOF”	8	800 µs	3	300 µs
“ EOP”	N/A	N/A	4	400 µs

During the absence of the chirp, that is the inferior state, and during the 14µs quiet time in the superior state a continuous scheme is enabled to check the availability or the occupancy of the channel. Figure 2, below shows an example of data pattern

During the packet body part, the two different states are the superior01 and superior02 that encode the different symbols. The two states are differentiated by just reversing the phase of the carrier at the beginning of every new data symbol occurrence. For example two consecutive “1” would be two chirps of equal length but with a 180° phase shift with respect to each other. A “0” symbol will consist of two consecutive chirps of same length and same phase. At the occurrence of another “0”, there would be two consecutive chirps having a 180° phase shift with respect to the two previous ones. The superior01 is stated as phase one, and superior02 is stated as phase two. This type of modulation is known as Phase Reversal Keying (PRK) shown in Figure 3.

5.1 Preamble data pattern

The first part uses the ASK type modulation, and it consists of eight “1” or “0” symbols followed by a preamble end of frame (PRE-EOF). Whenever the preamble is encoded, the first symbol whether it is a “1” or “0” must be encoded as a superior state. After the preamble data, follows the PRE-EOF, which consists of eight superior states (i.e.: eight consecutive chirps of 100µs with no additive quiet time) to terminate the preamble part.

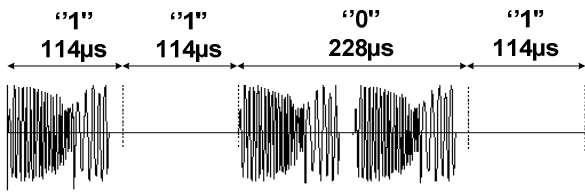

Figure 2. Preamble Encoding Data Pattern

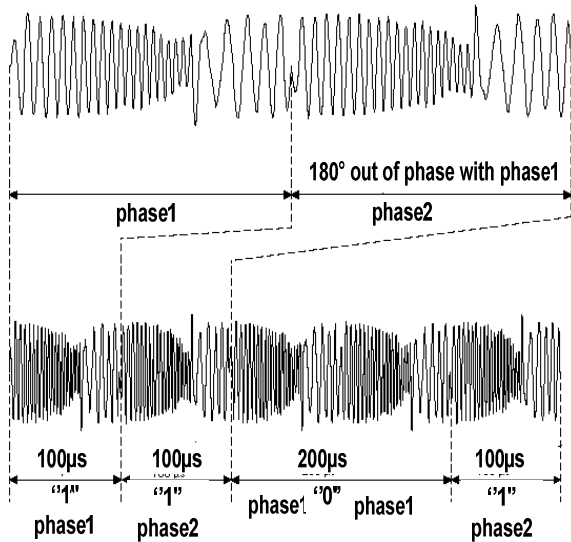
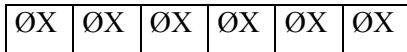
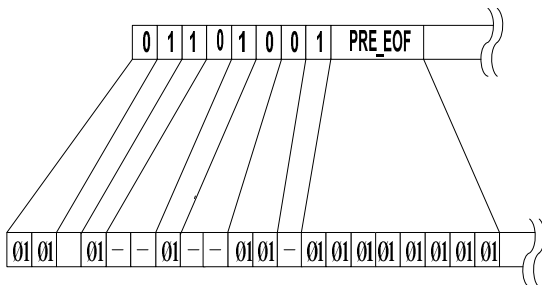

Figure 3. Phase Reversal Keying (PRK) Data Pattern
Example-Preamble data pattern:



Preamble symbols to be transmitted.
 “0” “1” “1” “0” “1” ”0” “0” “1” + PRE-EOF



Ø1: Superior state
 — : Inferior state

B. Packet body pattern

After the end of transmission of the Preamble_EOF, the following symbols of the packet body transmitted using PRK must obey to a certain rule. The superiorØ1 state will be in phase with the PRE-EOF. The first symbol following the PRE-EOF must be encoded with the opposite state of the PRE-EOF. The data packet will end with an End of Packet (EOP) symbol as: “1111” or “0000”

Example-Packet data pattern:

a)Beginning of packet

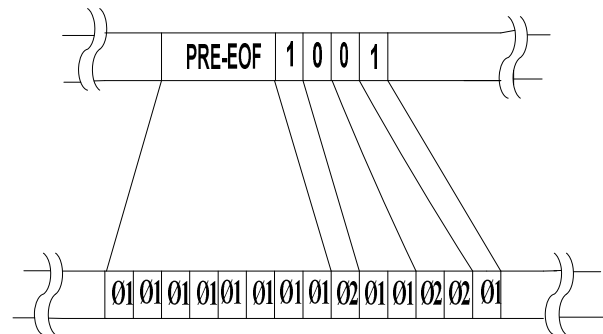

PRE-EOF: Preamble end of frame
 End of Packet

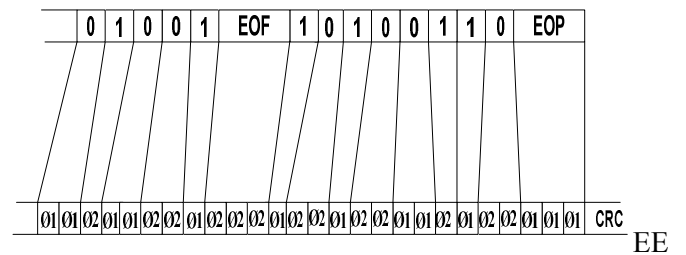

OF: End of Field, EOP: End of Packet
 Ø1: SuperiorØ1 (phase 1)
 Ø2: SuperiorØ2 (phase 2) ØX: Ø1 or Ø2
 CRC: Cyclical Redundancy Check

At the end of each transmitted packet, a 16-bit Cyclical Redundancy Check (CRC) is added to improve the reliability of the communication. The physical layer is in charge of the generation and the detection of all CRC's. Upon the detection of the PRE-EOF, the CRC is computed and transmitted. The CRC is appended to the packet and transmitted following the EOP.

4 Home Automation: Technology description

To control the various devices used in the business offices or at home, a mean of optimization is required. All devices are plugged on the mains, and then they are identified and taken in charge by control systems. These techniques used to perform the required tasks for networked business or home devices lead to automation. Therefore, Business or Home Automation signifies: all the rules, standards, control and communication systems, and operating systems must be undertaken to achieve the best integration between various components. Home Plug and Play (HomePnP) applied to Home automation is a resulting technique where any device in a system or subsystem comes with a built-in capability to be identified and to readily interact with other devices present in the network. HomePnP subsystems are harmonized with the activities of the homeowner and other subsystems. For example, a sending subsystem is able to notify all the listening systems that it is in a ready state. In response, a lighting subsystem is enabled to switch to a live-in-look mode,

and a windows control subsystem will not allow opening a window without expressed homeowner intervention.

Interoperation among subsystems permits a basic level of integration. Home devices communicate over a variety of home networks. Physical media for home networks include twisted pairs, coaxial cables, power lines and wireless RF and Infra Red carriers. HomePnP set the rules to enable a home control device to query or control another home device using any home network available in the home. HomePnP is developed in order to provide application level communication and interoperation between subsystems regardless of the lower level protocols [7].

Home automation protocols, classified in terms of the Open System Intercommunication (OSI) communication models, define physical layer, data links, and network components and as well as the application layer. Physical and data link protocols are specific to physical home networks. CEBus defines its own physical and data link protocols for power lines, twisted pairs, coaxial cables, and other media. Network protocol operates on top of any physical and data link protocols which are referred as low-level or transport-level protocols. These protocols describe how data is sent between two devices. Application-level protocols describe Home automation commands and responses that can be exchanged between devices.

HomePnP uses the Common Application Language (CAL) and the application layer of EIA 600. CAL is a language sufficiently complete and flexible enough to support a wide variety of devices. Figure 4 describes the overall diagram of the composing elements of an application process used in Home automation and HomePnP networks.

An application process is the device domain that performs the information processing. It can be a person, a processor, or both. The link to the Application layer is done by the User element (UE). The role of the UE is to call on the services of the CAL element. The Layer System Management (LSM) is the administrator of the functions that perform tasks across different layers. CAL is the language used for communication by the devices connected to the network and comply with it. Resource allocation is a function contained in the CAL. It is the other name for the functions of requesting, using, and releasing network resources that includes device address, group address, and data channels. It generates the Application Service Data Unit (ASDU) by using the CAL systems that request, assign, or release network resources. The CAL in turns calls the services of the Message Transfer Element (MTE) to deliver the ASDU to the destination. MTE is the communication element in the Application layer. It handles the ASDU's that are generated either internally or as a result of an application.

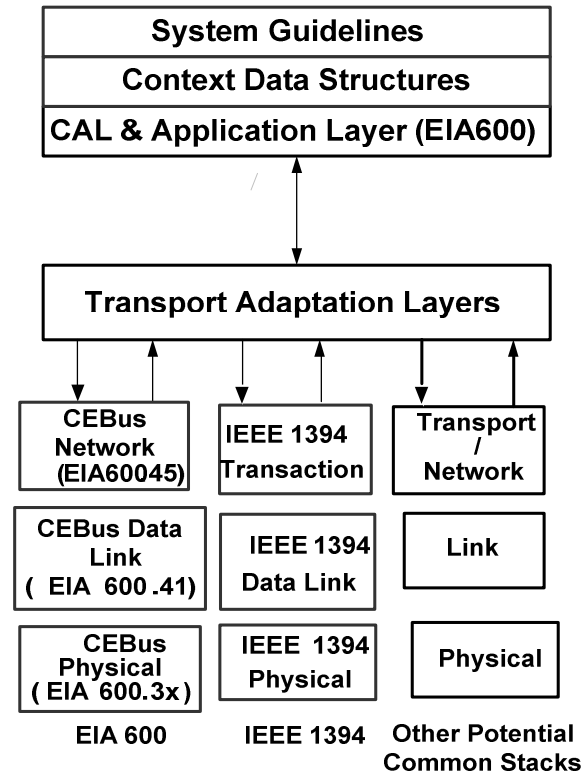

Figure 4 Application Diagram

The MTE assembles the Application Protocol Data Unit (APDU) and passes it directly or via the Associated Control Element to the Network Layer. Figure 5 illustrates the above different elements.

4.1 HomePnP Architecture for Interoperability

This architecture may be depicted in five different layers of constructs. The most basic begins with the basic CAL building blocks that are documented in EIA600. They include the concepts of addressable devices, contexts, contexts numbers, and sets of objects that contain instance variables, a reporting mechanism, and a set of transport-level services. In the second layer are added building blocks of subsystems for status, listener objects, sensors, alarms, and subsystems for developing and sharing house mode information. The third layer concerns the mechanisms for creating interoperability between HomePnP devices and subsystems. These mechanisms contain default binding, loose coupling, dynamic context numbers, status information, and state vectors. In the fourth layer, is described the use of tightly coupled objects for intra-subsystems. The final layer adds other elements essential for interoperation.

4.2 HomePnP Architecture for Interoperability

This architecture may be depicted in five different layers of constructs. The most basic begins with the basic CAL building blocks that are documented in EIA600. They include the concepts of addressable devices, contexts, contexts numbers, and sets of objects that contain instance variables, a reporting mechanism, and a set of transport-level services. In the second layer are added building blocks of subsystems for status, listener objects,

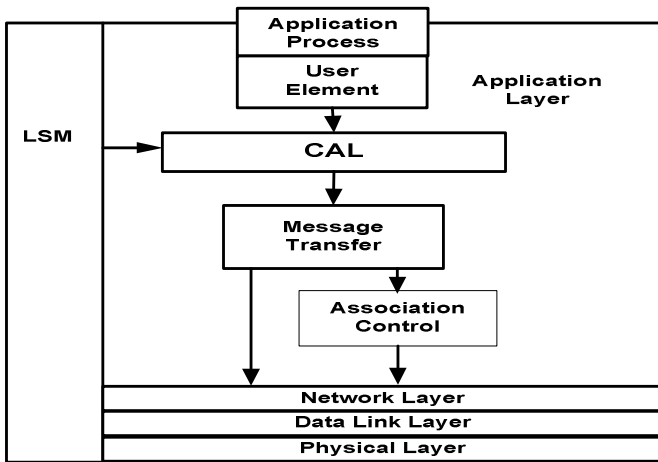

Figure 5. Application Layers Interface

sensors, alarms, and subsystems for developing and sharing house mode information. The third layer concerns the mechanisms for creating interoperability between HomePnP devices and subsystems. These mechanisms contain default binding, loose coupling, dynamic context numbers, status information, and state vectors. In the fourth layer, is described the use of tightly coupled objects for intra-subsystems. The final layer adds other elements essential for interoperation.

4.3 Basic Used Building Blocks

Various levels of products may be constructed using CAL: building of context, objects, and instance variables. These may be sensors, actuators, single-function devices, or multi-function devices. CAL gives a standard set of object definitions that are:

Object: a CAL term used to define a single control function within a context.

Context: a group of one or more CAL objects representing a common device function. Several contexts may be present in a single device.

Device: a mechanism that exposes state and control variables through a home network using the CAL protocol. Devices may be stand-alone hardware devices or may be implemented in software on a PC.

The first elementary HomePnP building block is the subsystem construct. A subsystem is a device that manages a major set of functions within a home automation system. Subsystems may include: security system, lighting system, environmental system, utility system, and entertainment. system. A subsystem contains a set of CAL contexts that are responsible for a part of a control region. Also, it typically consists of controllers and other hidden or exposed functions. A subsystem may reside in a single device or may be spread over many devices[8].

4.4 Interoperability

Subsystems can interoperate within their own subsystem or with other subsystems. CAL context models allow

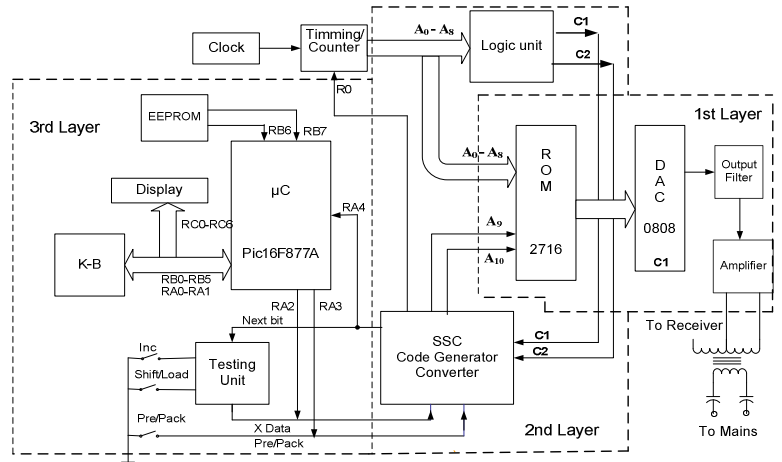

Figure 6. Circuit Block Diagram

interoperation between context within a subsystem (intrasubsystem) and across subsystems (intersubsystem).

5 Design Procedure

This paper concerns the realization of three practically defined layers as shown in Fig.6. The first physical layer is the hardware conversion of UST symbols to the generation of chirps and their coupling to the mains. The second physical layer concerns the conversion of binary data to the CEBus symbols that are “1”, “0”, “EOF”, and “EOP”; and their sending to the first physical layer. The third layer deals with the construction of preamble and packet messages issued by the higher layers.

The chirp signal, resulting from the first layer, is the main signal in Spread Spectrum Carrier Technology. It has been defined by Intellon by its shape and duration. It is composed of 360 points values to be stored in a ROM and then converted in an interval of time of 100µs to the shape described in section III. In the practical realization, the chirp is stored in four different forms: as a superior state composed of one chirp plus fifty 00H values for the 14µs quiet time, as an inferior state composed of 360 + 50 times 00H values, as one individual chirp of 360 values for the Superior01 state, and as a 180° out of phase individual chirp for the Superior02 state. The two first forms are used for the preamble part of a transmission, and the two others for “EOP”, “EOF”, and the packet message. The selection of one form or the other is controlled by the nature of symbols and message with the help of several control lines (C1, C2, Pre/Pack in the block diagram as in Figure 6.). The four forms are then converted from binary forms (in the ROM) to an analog waveform (i.e.: the chirp waveform) by the DAC 0808 IC. After amplification and filtering, the chirp signal is superposed to the 240v mains through a coupling circuit.

5.1 Packet Message Construction

The packet message construction takes place in the third

layer where a microcontroller is used to assemble the proper data contained in the transmitted packets. Higher levels; Data Link Layer, and the Application Layer are not implemented. A CEBus packet frame can be depicted into several parts that are: the Link Protocol Data Unit (LPDU), the Network Protocol Data Unit (NPDU), the Application Protocol Data Unit (APDU), and the CAL message. Figure 7 shows details of the packet structure. CAL uses a hierarchical model to describe each node. Each node includes two or more contexts, each made up of two or more objects. Each object includes one or more Instance Variables (IVs)

The first context in every node is named the Universal Context and has nothing to do with normal operation of the concerned device. The Universal Context is numbered 00 and its task is to control the device's presence on the network. The Universal Context contains two objects: the node control object (object 0) and the context control object (object 1).

The node control object consists of IVs to hold universal device information such as the device address, manufacturer name, and other device management information. The context control object possesses only one IV called object list (IDs). Every context is composed of one or more IVs that control or publish certain aspects of the device [6].

CAL defines other contexts which can be grouped. For instance, the Lighting Control context numbered 21 contains parameters used to define a light switch. The Lighting context has two objects. The context control object is the first object (object 1) and has one IV which is the object list containing the different objects which is 02010702. This can be read as the Lighting Context 21 has a CAL object of class 02 for the first (01) object and a CAL object of class 07 (example of analog control: light level control) for the second (02) object [7]. The CAL object 07 (class 07) is an analog control object and has 14 IVs. Part of these IVs is used. In this example, five IVs are used. The current value stores the current dim value in percent (0-100). The step rate and step size are used to set the ramp rate of the current value IV used for dimming and feature select is used to manipulate the current value IV and control the light. To construct a complete CAL message for the light switch to turn on and off, set to a dim level, or brought to a ramp level, various data set before the proper CAL statements are required. These data are defined in the different headers (LPDU, NPDU, APDU).

6.Conclusion

The use of power line has become very attractive for many applications: industries, business, home, and services. This has been possible with the advent of the new spread spectrum and the telecommunication technologies.

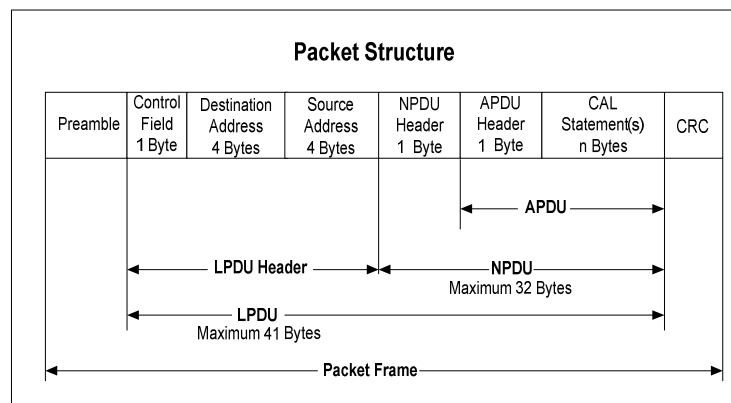

Figure 7 Packet Structure

Highly integrated circuit with powerful capabilities in the implementation of algorithms for coding, error detection, protocols application, and elaborated techniques of modulation has enabled the realization of networked control systems. Here, this paper describes the so called Home Automation with the spread spectrum technique on the power line in order to meet energy management objectives in terms of improved overall efficiency. The realized system completed in its three layers has met the projected goal. SSCT chirps signals, relying on hardware circuitry, have been obtained accordingly to the standard. Coupling these signals to power lines requires more care because of the harsh nature of the mains.

References

- [1] M.H Shwehdi, A.Z Khan, A power line data communication interface using spread spectrum technology in home automation, *IEEE Transactions on power Delivery*, Vol.11, 1996, pp. 1232 -1237.
- [2] R. Capelleti; A. Baschirotto, "A Versatile Low-Power Line FSK" Transceiver", *IEEE Custom Integrated Circuits Conference*, pp 1-4 Vol 14-6,2000.
- [3] G. Platt, Domestic Power Line Communication", University of Newcastle Australia, Electrical Engineering Project Report, October 1999.
- [4] J.O. Onunga and R. W. Donaldson, Distribution Line Communications using CSMA access control over electrical power lines, *IEEE Transactions on Power Delivery*, vol 4, no 2, April 1989. Page(s): 878-881.
- [5] D.Radford ,New Spread Spectrum Technologies Enable Low Cost Control Applications for Residential and Commercial Use, *Intellon Corporation*,2003.
- [6] " Overview of the Interoperability Model",Intellon, HomePnP specification, April 1998, pp5-59
- [7] White Paper #0027,CEBus Power Line Encoding and signalling",Intellon, , March 1997. pp. 1-6.